

IC- Gate valves

IC Gate valves:
Innovative, with many applications

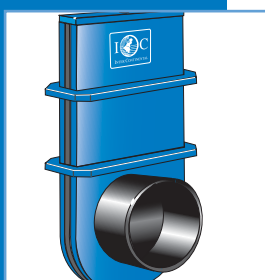
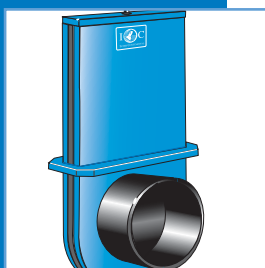
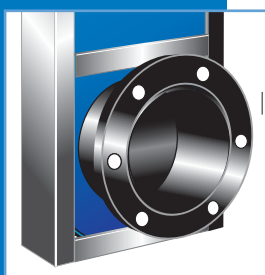

Gate valve for slurry and sludge removal

Gate valves from Inter Continental: Important !

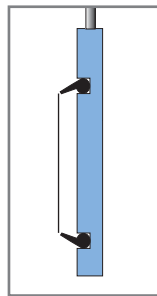
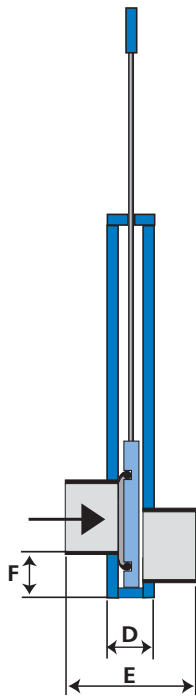
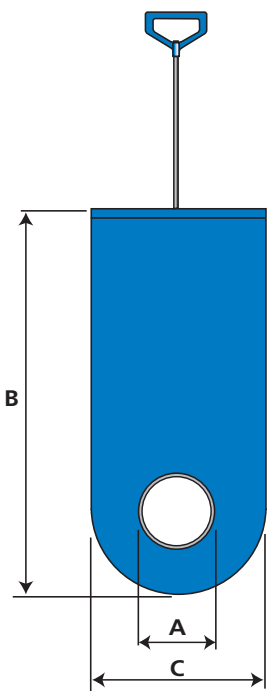

single rubber

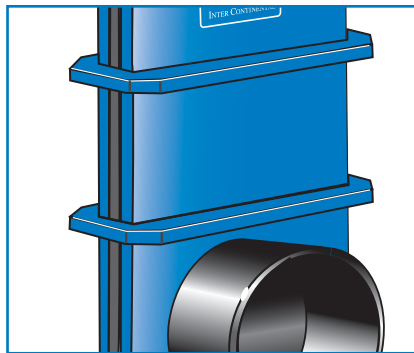
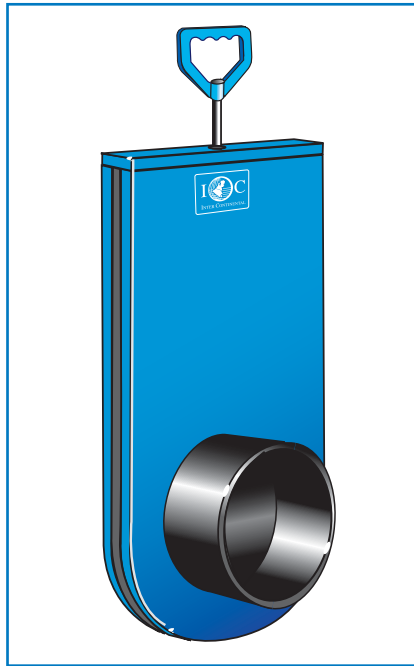

*Types 250/315/400 have reinforcement ribs

low pressure

Inter Continental gate valves may only be connected to the pipework with a socket. The valves may not be closed at a rate exceeding 2 cm per second.

You must ensure that the valves are always properly supported and are never suspended from the pipework.

The valve must always be mounted in such a way that it can always be replaced.

After installation, the pipework must first be well flushed through to remove any loose debris. When installing the valve, ensure that no adhesive remains can enter the valve, since this can interfere with proper functioning.

Inter Continental gate valves leave our factory after final inspection in perfect condition. Because it is impossible for us to continue supervision during transport and assembly after delivery, we accept no liability for possible consequential damage.

Guarantee claims can only be handled if the returned valve is accompanied by photos of the valve as it was installed.

IC-S

Incorrectly installed valves are not guaranteed.

ordernr.	type	A	B	C	D	E	F	max.pressure (bar)
MAFSL 110 S	Ø110	110	445	225	60	270	59	0,3
MAFSL 125 S	Ø125	125	445	225	60	270	51	0,3
MAFSL 160 S	Ø160	160	520	260	60	270	51	0,2
MAFSL 200 S	Ø200	200	545	300	60	270	51	0,2
MAFSL 250 S*	Ø250	250	640	350	60	350	51	0,2
MAFSL 315 S*	Ø315	315	767	410	60	350	47	0,2
MAFSL 400 S*	Ø400	400	940	500	60	350	51	0,2
extended model, with hook- or handle operation:								
MAFSL 110 SLV	Ø110	110	1250	225	60	270	59	0,3
MAFSL 160 SLV	Ø160	160	1250	260	60	270	51	0,2
MAFSL 200 SLV	Ø200	200	1250	300	60	270	51	0,2
MAFSL 250 SLV*	Ø250	250	1250	350	60	270	51	0,2
MAFSL 315 SLV*	Ø315	315	1250	410	60	350	47	0,2
MAFSL 400 SLV*	Ø400	400	1250	410	60	350	47	0,2

bigger diameters on request



available uptill length 2000

When gate valves are installed in poured concrete, you must always use a framework. When mounted in sand use a PVC tube around the valve for protection. This is to prevent the valve from becoming distorted and thus unusable.

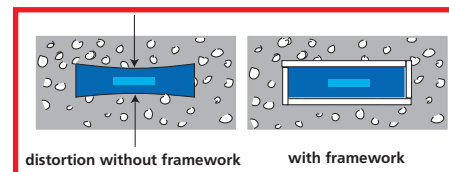

type IC-SL:

Gate valve for slurry, sludge and water removal

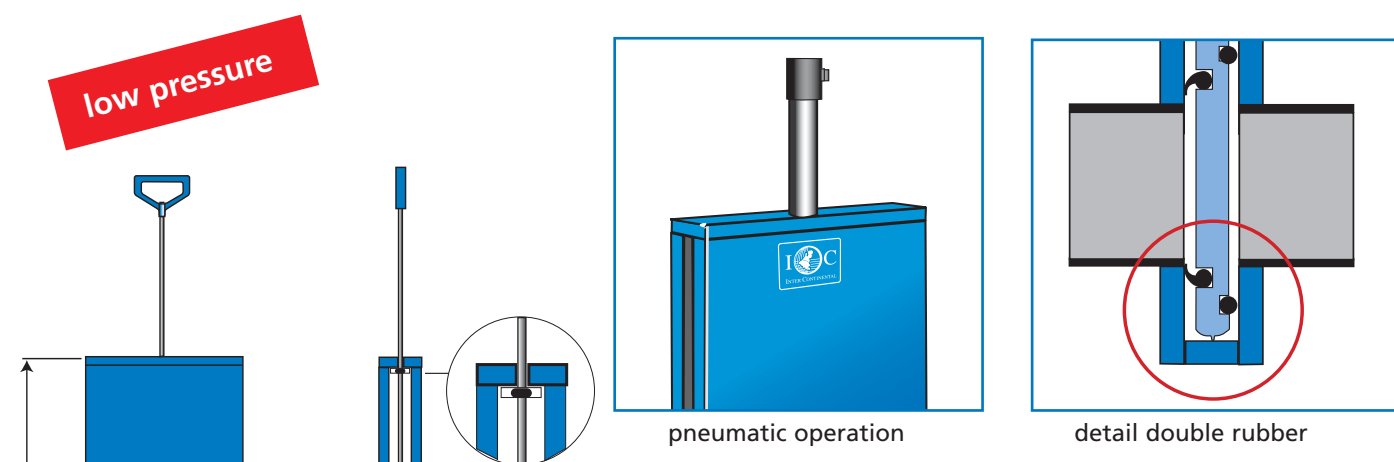

IC-SL

Ordernr.	type	A	B	C	D	E	F	max. pressure (bar)
RAFSL 110 SL	Ø110	110	550	245	60	270	79	0,3
RAFSL 125 SL	Ø125	125	550	245	60	270	81	0,3
RAFSL 160 SL	Ø160	160	625	280	60	270	81	0,3
RAFSL 200 SL	Ø200	200	650	320	60	270	81	0,2
RAFSL 250 SL	Ø250	250	745	370	60	350	81	0,2
RAFSL 315 SL	Ø315	315	872	430	60	350	81	0,2
RAFSL 400 SL	Ø400	400	1045	520	60	350	81	0,2

type IC-SLH:

Gate valve with stainless steel frame, for slurry, sludge and water removal



IC-SLH

Ordernr.	type	A	B	C	D	E	F	max. pressure (bar)
RAFSL 110 SLH	Ø110	110	550	245	60	270	79	0,3
RAFSL 125 SLH	Ø125	125	550	245	60	270	81	0,3
RAFSL 160 SLH	Ø160	160	625	280	60	270	81	0,3
RAFSL 200 SLH	Ø200	200	650	320	60	270	81	0,2
RAFSL 250 SLH	Ø250	250	745	370	60	350	81	0,2
RAFSL 315 SLH	Ø315	315	872	430	60	350	81	0,2
RAFSL 400 SLH	Ø400	400	1045	520	60	350	81	0,2

double rubber

bigger diameters on request

type IC-HP:

Gate valve for slurry, sludge and water removal for high pressure purposes up to 6 bar

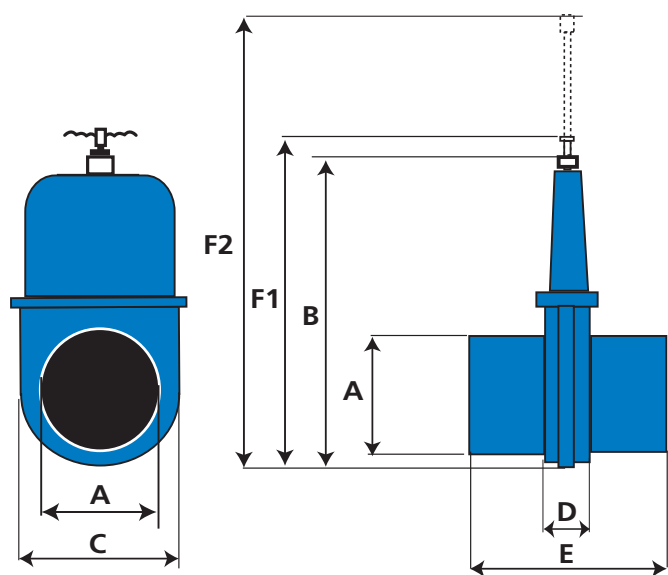

high pressure



PVC up to 6 bar



cast iron / stainless steel up to 10 bar

IC-HP

ordernr.	type	A	B	C	D	E	F1	F2	max.pressure (bar)
MAFSL 125 SF	Ø125	125	375	251	120	306	428	552	3
MAFSL 160 SF	Ø160	160	454	286	120	306	506	666	3
MAFSL 200 SF	Ø200	200	531	324	120	406	583	781	3
MAFSL 250 SF	Ø250	250	631	374	120	406	683	931	2,5
MAFSL 315 SF	Ø315	315	757	439	120	406	809	1118	2,5

IC Gate valves:
Innovative, with many applications



Inter Continental Ysselsteyn BV
Agrobaan 4
NL-5813 EB Ysselsteyn
T +31 (0)478 541 229
F +31 (0)478 542 107
E info@intercontinental.nl
I www.intercontinental.nl